

## LM3647

# Universal Battery Charger for Li-Ion, Ni-MH and Ni-Cd Batteries

### General Description

The LM3647 is a charge controller for Lithium-Ion (Li-Ion), Nickel-Metal Hydride (Ni-MH) and Nickel-Cadmium (Ni-Cd) batteries. The device can use either a pulsed-current charging or a constant-current charging technique. The device can also be configured to discharge before charging. Throughout the charging sequence the LM3647 monitors voltage and/or temperature and time in order to terminate charging.

Charge termination methods are:

- Negative delta voltage ( $-\Delta V$ )
- Optional: Delta temperature/delta time ( $\Delta T/\Delta t$ )
- Backup: Maximum temperature
- Backup: Maximum time
- Backup: Maximum voltage

If both voltage and temperature fail to trigger the termination requirements, then the maximum time (configured by external hardware) steps in which terminates the charging.

In Ni-Cd/Ni-MH mode, four different charging stages are used:

- Soft-start charge
- Fast charge
- Topping charge
- Maintenance charge

In Li-Ion mode, four different charging stages are used:

- Qualification
- Fast Charge Phase 1, Constant Current
- Fast Charge Phase 2, Constant Voltage
- Maintenance charge

The charge current of the LM3647 is configured via external resistors, which in turn controls the duty cycle of the PWM switching control output. For cost-sensitive applications, the LM3647 charge controller can be configured to use an external current source and no temperature sensor.

When using an external current source, the current is controlled by the LM3647 which turns the current source on and off. The LM3647 automatically detects the presence of a

battery and starts the charging procedure when the battery is installed. Whenever an error occurs (e.g., short circuit, temperature too high, temperature too low, bad battery, charge time over, etc.) the LM3647 will stay in error mode until the battery is removed or it gets within the allowed charging temperature range. The LM3647 is available in a standard 20-lead SOIC surface mount package.

### Features

- Auto-adaptive fast charge
- High-resolution, accurate voltage monitoring prevents Li-Ion undercharge or overcharge
- Fast charge, pre-charge and maintenance currents are provided. Different currents are selectable via external resistors.
- Fast-charge termination by  $\Delta$  temperature/ $\Delta$  time, maximum voltage, maximum temperature, negative  $\Delta$  voltage and maximum time
- Dynamically detects battery insertion, removal, short circuit and bad battery without additional hardware
- Supports charging of battery packs with 2–8 cells of Ni-Cd/Ni-MH or 1–4 cells of Li-Ion (1 cell of NiCd/NiMH can be supported by added external 2x voltage amplifier)
- Three optional LED indicators and Buzzer output indicate operational modes
- Ni-MH/Ni-Cd charge mode, Li-Ion charge mode or discharge mode can be selected manually
- Supports control of current feedback power supply and constant current power supply

### Applications

- Battery charging systems for:
  - Portable consumer electronics
  - Audio/video equipment
  - Communications equipment
  - Point of sale devices
  - Power tools
  - Personal convenience products

## 2.0 Connection Diagram

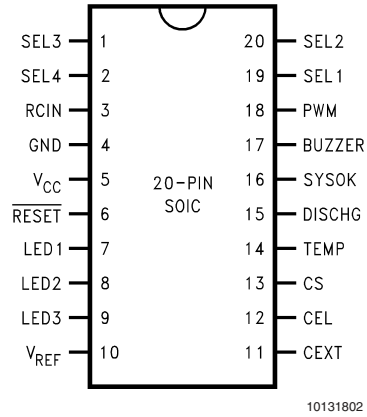

**Top View**  
**Order Number LM3647IM**  
**See NS Package Number M20B**

### 2.1 PIN DESCRIPTIONS

Pin No.	Name	I/O	Description
1	SEL3	I	Input to Select Power Source or Li-Ion Cell Voltage
2	SEL4	I	Input to Select Maintenance Charge Time Out, Connected to an RC-Network
3	RCIN		RC-Timing Pin
4	GND		Ground
5	V <sub>CC</sub>		5V, Power Supply
6	RESET	I	Reset Pin, Active Low
7	LED1	O	LED Output
8	LED2	O	LED Output
9	LED3	O	LED Output
10	V <sub>REF</sub>	I	Voltage Reference Analog Input
11	CEXT		External Capacitor
12	CEL	I	Battery Voltage Input (through resistor divider)
13	CS	I	Current Sense Input
14	TEMP	I	NTC-Temperature Sensor Input
15	DISCHG	O	High when Discharging, Else Low
16	SYSOK	O	System Monitor Output
17	BUZZER	O	Buzzer Output
18	PWM	O	Charge Control Output
19	SEL1	I	Tri-Level Input, Discharge/Maintenance Charge Select
20	SEL2	I	Tri-Level Input, Battery Type Select (NiCd, NiMH, Li-Ion)

### 2.2 ORDERING INFORMATION

Device	Package	Temperature
LM3647	20 SOIC	-40°C to +85°C

# Typical Application

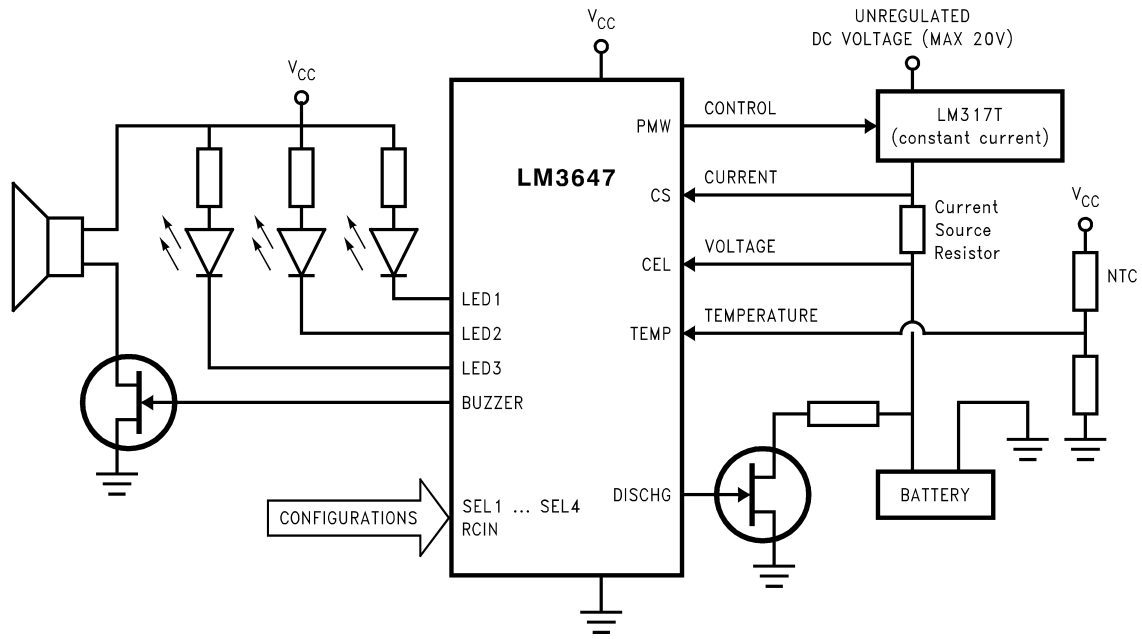

10131801

### 3.0 Electrical Characteristics

#### Absolute Maximum Ratings (Note 1)

If Military/Aerospace specified devices are required, please contact the National Semiconductor Sales Office/Distributors for availability and specifications.

Supply Voltage ( $V_{CC}$ )	7V
Voltage at Any Pin	-0.3V to $V_{CC}$ +0.3V
Total Current into $V_{CC}$ Pin (Source)	100 mA

Total Current out of GND Pin (Sink)	110 mA
Storage Temperature Range	-65°C to +140°C

**Note 1:** Note: Absolute Maximum Ratings indicate limits beyond which damage to the device may occur. DC and AC Electrical Specifications are not ensured when operating the device at absolute maximum ratings.

#### DC Electrical Characteristics

-40°C ≤  $T_A$  ≤ +85°C unless otherwise specified.

Parameter	Conditions	Min	Typ	Max	Units
Operating Voltage		4.5		5.5	V
Supply Current			2.5		mA
LED-pin Sink Current		7.5		15	mA
Temperature Input Levels					
Ni-Cd/Ni-MH Upper Limit	(Voltage at TEMP-pin)		3.15		V
Li-Ion Upper Limit	(Voltage at TEMP-pin)		3.0		V
Lower Limit	(Voltage at TEMP-pin)		0.5		V
Start Limit	(Voltage at TEMP-pin)		2.2		V
L-Ion (for both 4.1 and 4.2V Cells)					
Maintenance Charge Minimum Voltage	(CEL pin)		2.6		V
Maintenance Charge Restart Voltage	(CEL pin)		2.153		V
Good Battery Threshold	(CEL pin)		1.2		V
Maintenance Current	(Voltage at CS-pin)		2.3		V
Maintenance Current Lower Threshold	(Voltage at CS-pin)		2.42		V
Minimum Current Fast Charge	(Voltage at CS-pin)		2.3		V
Termination					
Qualification Current	(Voltage at CS-pin)		2.3		V
Maximum Charging Current	(Voltage at CS-pin)		1.5		V
Ni-Cd/Ni-MH					
Maximum Battery Voltage	(CEL pin)		3.017		V
Maximum Battery Current	(Voltage at CS-pin)		1.5		V
Battery Presence Limit	(CEL pin)		1.0		V
Discharged Battery Limit	(CEL pin)		1.7		V
Good Battery Threshold	(CEL pin)		1.2		V
Soft Start Current	(Voltage at CS-pin)		2.3		V
Topping Charge Current	(Voltage at CS-pin)		2.3		V
Maintenance Charge Current	(Voltage at CS-pin)	2.425	2.45		V
$V_{REF}$				2.5	V

#### AC Electrical Characteristics

Parameter	Conditions	Min	Typ	Max	Units
RCIN Frequency	R = 3.3 kΩ, C = 68 pF		2.5		MHz
Fast-PWM Frequency			250		Hz
Slow-PWM Frequency			0.1		Hz

## 4.0 Functional Description

### 4.1 GENERAL

The LM3647 can be configured to charge three different types of batteries: Ni-Cd, Ni-MH and Li-Ion. The charger behavior for Ni-Cd and Ni-MH is similar but the charge curves will appear slightly different due to the differences in chemistry. The Ni-Cd/Ni-MH charging algorithm is divided into four phases:

**Soft Start:** The LM3647 detects that a battery is connected and optionally verifies that the temperature is within safe operating limits (approx.  $-5^{\circ}\text{C}$  to  $+50^{\circ}\text{C}$ ). Charging starts with a current of 0.2C and switches into the next phase after approx. 5 minutes. Error termination will be triggered by Maximum Battery Voltage (CEL-pin  $> 3.017\text{V}$ ) or if the battery voltage does not reach the defective battery level (CEL-pin  $< 1.2\text{V}$ ).

**Fast Charge:** Constant current is applied to the battery and the LM3647 monitors voltage and temperature (optional). Switching into the next phase will appear after a voltage drop in the charging curve: Ni-Cd  $\sim 50\text{mV/cell}$  and Ni-MH  $\sim 17\text{mV/cell}$ . Error termination will be triggered by over-temperature.

**Topping Charge:** A current of 0.2C is applied to the battery for a user defined time (RC network at SEL4).

**Maintenance Charge:** Is user selectable and is a fixed percentage of the Fast Charge rate. Discharge before charge is user selectable.

#### Ni-Cd Charging Curve:

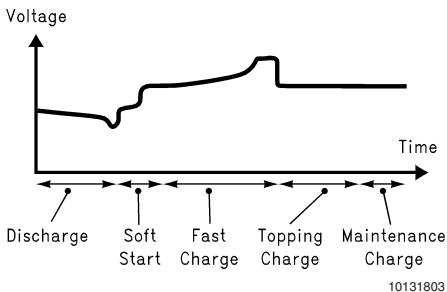

#### Ni-MH Charging Curve:

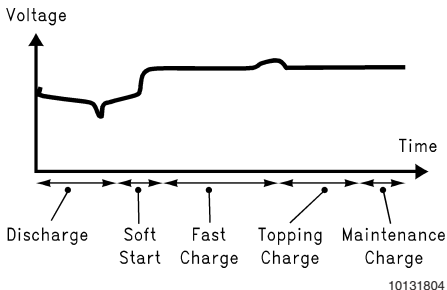

The Li-Ion charging algorithm is also divided into four phases:

- Qualification:** The LM3647 detects that a battery is connected and verifies that the temperature (optional but highly recommended for safety reasons) is within limit. Charging starts with a current of 0.2C and switches into

next phase after approx. 1 minute. Error termination will be triggered if the battery voltage does not reach the Li-Ion battery qualification level (CEL-pin  $< 1.2\text{V}$ ) within one minute.

- Fast Charge Constant Current:** Battery voltage will rise until Maximum Battery Voltage (CEL-pin =  $2.675\text{V}$  or  $2.74\text{V}$  depending on SEL3) is reached.
- Fast Charge Constant Voltage:** Keeps the voltage constant until the current has decreased below the threshold (CS at  $2.3\text{V}$ ).
- Maintenance Charge:** Is user selectable and is a fixed percentage of the Fast Charge rate.

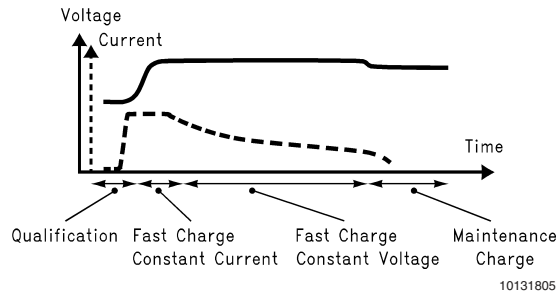

### 4.2 ADVANCED PIN DESCRIPTIONS

SEL1 is a selection pin to control the LM3647 discharge and maintenance charge modes. The pin has three states: tied to  $V_{CC}$ , GND, or unconnected (Hi-Z). When the charger is configured to charge Ni-Cd or Ni-MH batteries, this pin determines if the charger discharges the battery before charging or if the charger shall only maintenance charge the battery. When the charger is configured for Li-Ion batteries, this pin determines how the charger behaves during maintenance charge.

Charge mode	
SEL1	condition SEL2 = GND (NiCd) or $V_{CC}$ (NiMH)
$V_{CC}$	No discharge before charge
GND	Maintenance charge only (no fast charge)
Open	Discharge before charge
Charge mode	
SEL1	condition SEL2 = Open (Li-Ion)
$V_{CC}$	Maintenance charge indefinite
GND	Maintenance charge indefinite, restart fast-charge if battery gets discharged (load connected)
Open	No maintenance charge, restart fast charge if battery becomes discharged

SEL2 is a selection pin to determine the battery type to be charged. The pin has three states: tied to  $V_{CC}$  (Ni-MH), GND (Ni-Cd), or unconnected (Li-Ion).

SEL2	Battery Type Select
$V_{CC}$	Ni-MH
GND	NiCd
Open	Li-Ion

SEL3 is a selection pin used to set charger hardware modes. The pin has two states: tied to  $V_{CC}$  or GND. When the LM3647 is configured for Ni-Cd/Ni-MH batteries, this pin selects between a power supply with current feedback when

## 4.0 Functional Description (Continued)

tied to  $V_{CC}$  (PWM “fast” frequency) or a constant current source when tied to GND (PWM “slow” frequency). When configured for Li-Ion batteries, SEL3 switches between 4.1V cells or 4.2V cells.

**Note:** SEL3 must be hard wired to  $V_{CC}$  if a charger that supports both Li-Ion and Ni-Cd/Ni-MH is implemented.

SEL3	PWM Output Frequency Select output SEL2 = $V_{CC}$ (NiMH) or GND (NiCd)
$V_{CC}$	Current feedback (“fast” PWM frequency)
GND	No current feedback (external constant current source) (“slow” PWM frequency)
SEL3	Li-Ion Cell Voltage Select output SEL2 = Open (Li-Ion)
$V_{CC}$	4.2V/cell
GND	4.1V/cell

**Note:** Current feedback is automatically selected, if LM3647 is configured for Li-Ion charging (pin SEL2 open).

**SEL4** is connected to a RC-network that determines the charge time-outs. This RC-network is also connected to the output LED1. (See Section 4.3.2 for details).

**RCIN** is a high-speed timing pin connected to a RC-network, used to drive the charger at the right operating frequency.

**GND** is the ground pin.

**$V_{CC}$**  is the power-supply pin. This pin should have a 100 nF decoupling capacitor tied to GND.

**RESET** is a reset pin.

**LED1** is an active-low output used to indicate charge phase. It is also used when measuring the charge timeout value.

**LED2** is an active-low output used to indicate charge or discharge. It also sends out digitally what the LM3647 has read at the mode selection pins and charge timeout.

**LED3** is an active-low output used to indicate charge start/stop and error.

**$V_{REF}$**  is the voltage reference analog input. The LM3647 uses this pin as a reference when measuring the other analog inputs.  $V_{REF}$  has to be connected to a 2.5V voltage reference (e.g., LM4040A - 2.5).

**CEXT** is a timing pin used by the LM3647, it must be connected to a low loss capacitor (polyester).

**CEL** is an analog input that measures the battery voltage via a resistor divider network.

**CS** is an analog input that is connected to a differential amplifier that measures the voltage over a small current sensing resistor, when used in conjunction with current feedback power supply. When the LM3647 is used with a constant current power supply, CS should be connected to the 2.5V voltage reference (pin  $V_{REF}$ ).

**TEMP** is an analog input that is connected to the temperature sensing NTC-resistor (is used). If no temperature sensor is used, the input must be connected to a voltage between 0.5V to 2.2V.

**DISCHG** is a digital output that controls a power-FET that discharges the batteries before charging them. If the discharge function is not used, leave this pin unconnected.

**SYSOK** is an open drain output that resets the LM3647 in the rare case of an internal illegal operating condition. This pin is connected to the RESET pin to increase reliable operation of the device in hostile operating environments (e.g., noisy environments).

**BUZZER** is a digital output that controls a small FET and turns an optional buzzer on and off. The buzzer must have it's own oscillator drive circuitry.

**PWM** is a digital output that controls the charge voltage or turns the external current source on and off (depending on mode-selection).

## 4.3 CONFIGURATIONS

### 4.3.1 Maximum Battery Voltage

The maximum battery voltage corresponds to the number of battery cells. The resistor network in the figure below scales the battery voltage to a level suitable for the LM3647. For Ni-Cd/Ni-MH batteries the tolerance of the network is not critical, and only defines the maximum battery voltage (which is used as a backup termination method). For Li-Ion batteries the network must be more accurate, and resistors with low tolerances must be used (1% or better).

### Ni-Cd/Ni-MH

Each battery cell is at nominal voltage 1.2V, but the critical voltage is rather the maximum voltage per cell specified at 1.85V. The maximum cell voltage is used for maximum voltage error termination. If a Ni-Cd/Ni-MH cell fails, it either becomes shorted or goes high impedance. In the case of high impedance the cell voltage will reach 1.85V. By multiplying the number of cells with the maximum cell voltage, the Maximum Battery Voltage ( $V_{Batm}$ ) is achieved.

When the maximum battery voltage has been determined, the voltage divider network can be dimensioned using the following formula (SEL2 connected to  $V_{CC}$  or GND):

$$V_{Batm} \times \frac{R7}{(R6 + R7)} = CEL = 3.017V$$

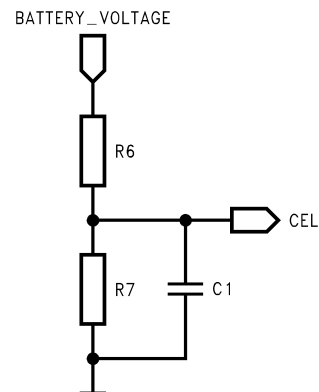

10131807

## 4.0 Functional Description (Continued)

Resistor network selection Quick Guide:

No. of Cells	Ni-Cd/Ni-MH			
	Nominal	Max	R6	R7
2	2.4V	3.7V	10k	43k
3	3.6V	5.55V	47k	56k
4	4.8V	7.4V	16k	11k
5	6V	9.25V	62k	30k
6	7.2V	11.1V	15k	5.6k
7	8.4V	12.95V	27k	8.2k
8	9.6V	14.8V	39k	10k
9	10.8V	16.65V	68k	15k
10	12V	18.5V	22k	3.9k

Example: A standard 9V Ni-Cd block battery is composed of 6 small Ni-Cd cells and therefore has a nominal voltage of 7.2V. See table above for resistor values.

### Li-Ion

The voltage divider network for Li-Ion must be selected with great care for maximum utilization of the batteries. Li-Ion battery cells have a nominal voltage of 3.6V or 3.7V and the maximum voltage per cell is specified at 4.1V or 4.2V respectively. By multiplying the number of battery cells with the maximum cell voltage, it is possible to determine the Maximum Voltage of the Battery Pack. When the maximum battery voltage ( $V_{Batm}$ ) has been determined, the voltage divider network has to be dimensioned using the following formula (SEL2 open):

Pin SEL3	
GND	$V_{Batm} \times \frac{R7}{(R6 + R7)} = CEL = 2.6750V$
$V_{CC}$	$V_{Batm} \times \frac{R7}{(R6 + R7)} = CEL = 2.740V$

The LM3647 supports two different user selectable battery input voltages on the CEL pin. These are 2.675V (SEL3 tied to GND) and 2.740V (SEL3 tied to  $V_{CC}$ ). This selection pin can be used to configure the charger to handle both 3.6V and 3.7V Li-Ion-cells, without changing the resistor values in the CEL pin voltage divider network. SEL3 can also be used to obtain a better match when choosing standard series resistor values for certain cell combinations.

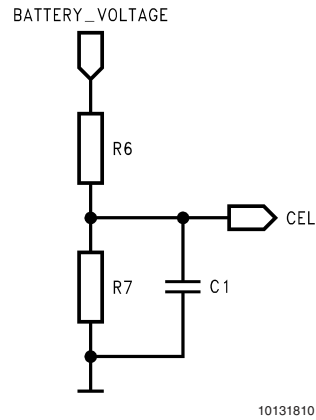

Resistor network selection Quick Guide:

No. of Cells	Li-Ion (3.6V cell)			
	Nominal	Max	R6	R7
1	3.6V	4.1V	16k	30k
2	7.2V	8.2V	62k	30k
3	10.8V	12.3V	27k	7.5k
4	14.4V	16.4V	22k	3.9k

No. of Cells	Li-Ion (3.7V cell)			
	Nominal	Max	R6	R7
1	3.7V	4.2V	16k	30k
2	7.4V	8.4V	62k	30k
3	11.1V	12.6V	27k	7.5k
4	14.8V	16.8V	22k	3.9k

### 4.3.2 Charge Timeout

The LM3647 uses the charge timeout value as a backup termination method if the normal termination methods fail. The charge timeout also controls the length of some of the phases, (e.g., the Topping Charge phase). The timeout is selectable by choosing different R-C values as shown in the table below:

R Value	C Value	Ni-Cd/Ni-MH Fast Charge (minutes)	Ni-Cd/Ni-MH Topping (minutes)	Li-Ion CC (minutes)	Li-Ion CV (minutes)
100 k $\Omega$	0 nF	75	20	50	75
100 k $\Omega$	10 nF	100	25	70	100
100 k $\Omega$	15 nF	160	40	110	160
100 k $\Omega$	22 nF	190	50	130	190
100 k $\Omega$	33 nF	260	65	170	260
100 k $\Omega$	47 nF	330	80	220	330
100 k $\Omega$	68 nF	450	115	300	450
100 k $\Omega$	100 nF	540	135	360	540

## 4.0 Functional Description (Continued)

### 4.3.3 Charge Current

Charge current selection depends on the type of power supply used. The LM3647 supports two types: current feedback and constant current. The PWM pin is used to control the power supply and depending on the supply type, it either produces a simple on/off signal (PWM slow, constant current supply) or a PWM signal that is filtered externally to a DC voltage to regulate the charge voltage in a current feedback power supply (PWM fast). (SEL3 = V<sub>CC</sub>, if SEL2 = GND or V<sub>CC</sub>; automatic if SEL2 = open.)

#### 4.3.3.1 Current Feedback Power Supply

A current feedback type power supply must be used if charging Li-Ion batteries. When a current feedback power supply is used, the charge-current is selected by setting the current

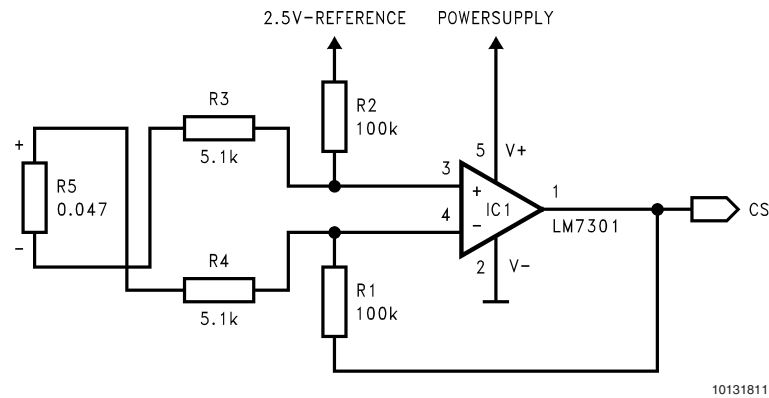

The current-sensing signal is amplified, inverted and centered on the 2.5V reference by the operational amplifier and fed into the CS pin on the LM3647. The amplification stage must be dimensioned by setting the appropriate ratio between R1 (R2) and R3 (R4). The figure above is dimensioned for a maximum current of about 1.1A. This was calculated using the following formula:

$$\text{MaxCurrent} = \frac{(R3)/(R1)}{R5} \times (V_{\text{REF}} - 1.5\text{V})$$

$$R1 = R2 \quad R3 = R4$$

Example:

$$R3 = 5.1 \text{ k}\Omega, R1 = 100 \text{ k}\Omega, R5 = 0.047\Omega, V_{\text{REF}} = 2.5\text{V}$$

$$\rightarrow \text{MaxCurrent} \approx 1.09 \text{ Ampere}$$

With a current feedback power supply the PWM pin must be configured for "fast" mode (SEL3 = V<sub>CC</sub>; if SEL2 = GND or V<sub>CC</sub>; automatic if SEL2 = open).

The RC-network R6, C9 and R5, C1/C2 lowpass-filters the PWM-signal from the LM3647 to a DC-level that is fed into the operational amplifier. The resistor R22 is required to prevent DC-output before the LM3647 has control of the RC-networks.

sensing resistor and the gain of the differential amplification stage. The current sensing resistor (R5) should be dimensioned such that a voltage drop over it is not too small, because the signal will be more susceptible to noise and offsets in the amplification-stage. The resistance should not be too large either (especially in high-current applications), because this will only generate more heat from the component. A suitable value is one that develops about 50 mV across the resistor when maximum current flows through it.

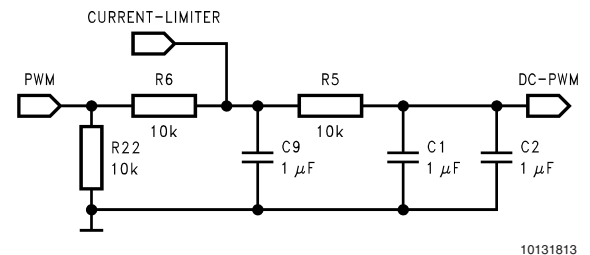

#### 4.3.3.2 Constant Current Power Supply

A constant current power supply can only be used with Ni-Cd/Ni-MH batteries, it can **not** be used to charge Li-Ion batteries. With a constant current power supply (NiCd/NiMH batteries only: SEL2 = GND or V<sub>CC</sub>) the PWM pin must be configured for "slow" mode (SEL3 = GND). In that mode the PWM-pin turns the external current source on and off at a rate of 0.1 Hz. (This example is just one of many possible design solutions.) The PWM-pin (SLOW\_PWM) turns the transistor Q1 on and off. When the transistor is off the current source is on, and when the transistor is on the current source is off (V<sub>OUT</sub> at approximate 0.7V). The value of R1 depends on the size of the charge current (see formula):

$$I_{\text{OUT}} = \frac{1.25 - V_D}{R1} \quad V_D = \text{Voltage Drop Across D1}$$



## 4.0 Functional Description (Continued)

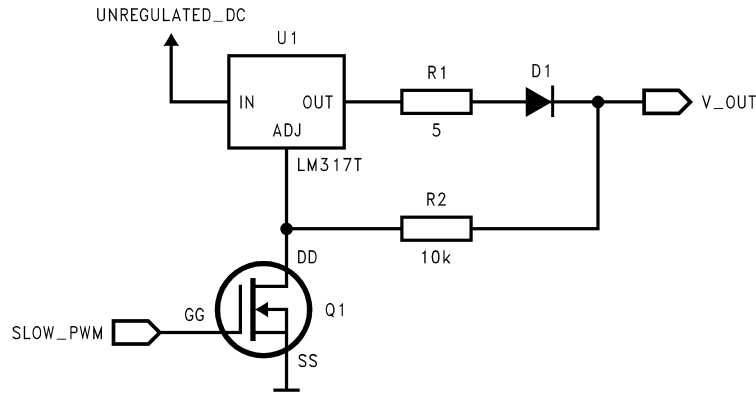

10131815

The charge current duty cycles for the different phases cycles are listed below:

Charge Phase	Charge Current Duty Cycle
Soft Start	10%
Fast Charge	100%
Topping Charge	10%
Maintenance Charge	5%

### 4.3.4 Dimensioning the Reset Circuitry

The reset-circuitry is designed to hold the RESET pin low until the power supply to the LM3647 has stabilized. The RC-network (R21 and C4) should be dimensioned in the following way:

$$(R21 \times C4) > 5 \times \text{PowerSupplyRiseTime}$$

The diode D2 discharges the capacitance C4 when power loss occurs. The resistor R20 is used to protect the SYSOK-pin, and its value is not critical (typical value is 2 kΩ). R20 can be eliminated if the SYSOK pin is not connected to RESET or if the value of C4 is ≤0.1 μF. The connection between RESET and SYSOK is optional but highly recommended for safe operation of the LM3647.

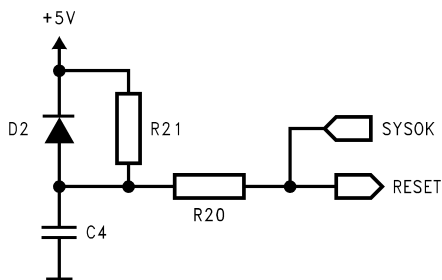

10131816

### 4.3.5 Dimensioning the RCIN Circuitry

The RC-circuitry is designed to time the charger so it charges and regulates at the correct frequency. The values of the R and C are important, because a change in the RC-value gives a higher or lower operating frequency which affects charge quality. The capacitance should be a ceramic type and preferably an NP0 type, which gives the least frequency deviation with temperature change.

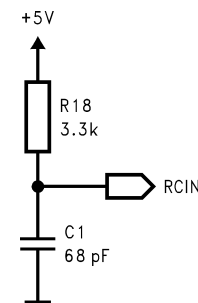

10131817

### 4.3.6 Dimensioning the DISCHARGE Circuitry

The discharge-circuitry controls the discharge rate during the discharge phase (if used). The discharge output turns on the transistor Q2, and a current flows from the battery through the discharge resistor R8. The current through R8 depends on battery voltage and the value of R8. This value depends on the maximum discharge rate for the battery pack. The approximate value can be calculated using the formula below:

$$R8 = \frac{\text{MaximumBatteryVoltage}}{\text{MaximumDischargeRate}}$$

The resistor R7 keeps the transistor Q2 off until the LM3647 has been powered up and is in control of the circuitry.

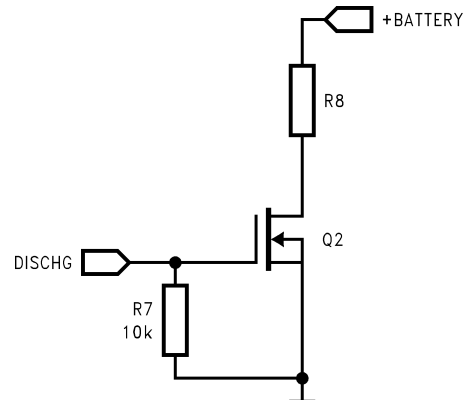

10131819

## 4.0 Functional Description (Continued)

### 4.3.7 BUZZER Output Circuitry

The buzzer-circuitry turns the transistor Q3 on when the buzzer should sound. If the current consumption for the buzzer is lower than 0.3 mA then the buzzer may be directly connected to the BUZZER-pin. Please note that the BUZZER-pin does not generate a PWM-signal, therefore the buzzer must have its own oscillator circuitry. If an electromagnetic buzzer is used, then the transistor may need a reverse-biased diode to protect it from harmful voltage spikes.

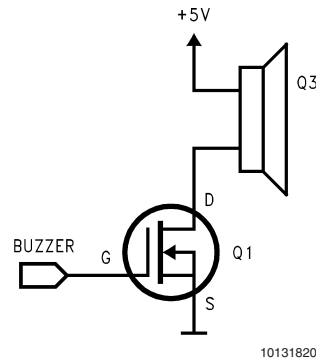

### 4.3.8 User Interface

The user interface consists of up to three LEDs and one buzzer. The LEDs have four different states:

On, off, slow flash (~1 Hz) and fast flash (~10 Hz). The buzzer has three different states: off, one short beep (~100 ms) and one long beep (~1s).

The user interface is designed in a flexible way. Use of the buzzer or the LEDs is optional, depending on design requirements. It is possible to use the LM3647 with one, two or all three LEDs.

A single "end of charge" Status LED can be implemented with a 2-input NAND gate on pins LED1 and LED3. In this implementation, note that a pull-up resistor is required on LED1 and LED3.

Ni-Cd/Ni-MH User Interface Scheme

Charge Phase	LED1 Status	LED2 Status	LED3 Status	Buzzer Status
No Battery	Off	Off	Off	Off
New Battery/Temp-Test	Fast Flash	Off	Off	Short Beep
Softstart Charge	Slow Flash	Off	Off	Off
Charging	On	Slow Flash	Off	Off
Topping Charge	On	Fast Flash	Off	Off
Maintenance	On	Off	On	Long Beep
Discharge	Off	Slow Flash	Off	Off
Temperature Error	2 Fast Flashes	Off	On	Short Beep
Error	Fast Flash	Off	Fast Flash	Short Beep

Li-Ion User Interface Scheme

Charge Phase	LED1 Status	LED2 Status	LED3 Status	Buzzer Status
No Battery	Off	Off	Off	Off
New Battery/Temp-Test	Fast Flash	Off	Off	Short Beep
Qualification Charge	Slow Flash	Off	Off	Off
Charging CC	On	Slow Flash	Off	Off
Charging CV	On	Fast Flash	Off	Off
Maintenance	On	Off	On	Long Beep
Temperature Error	2 Fast Flashes	Off	On	Short Beep
Error	Fast Flash	Off	Fast Flash	Short Beep

### 4.3.9 Recommended Dimensioning for the Temperature Sensor

The LM3647 is designed for use with a NTC resistor as a temperature sensor. The NTC should have 3 k $\Omega$  @ 25°C and a  $\beta = 3988$ . The voltage at TEMP-input must be between 2.2V and 0.5V for the charger to start. While charging, the voltage must stay between 3.0V (maximum temperature) for

Li-Ion, or 3.15V (maximum temperature) for Ni-Cd/Ni-MH, and 0.5V (minimum temperature) or the charger will register a temperature fault and abort the charge. These voltages correspond to the upper and lower limits for the battery pack temperature.

When no NTC is used the TEMP-input pin must be connected to a voltage level between 2.2V and 0.5V.

## 4.0 Functional Description (Continued)

Typical Configuration Curve, (NTC Characteristics: 3 kΩ @ 25°C, β=3988)

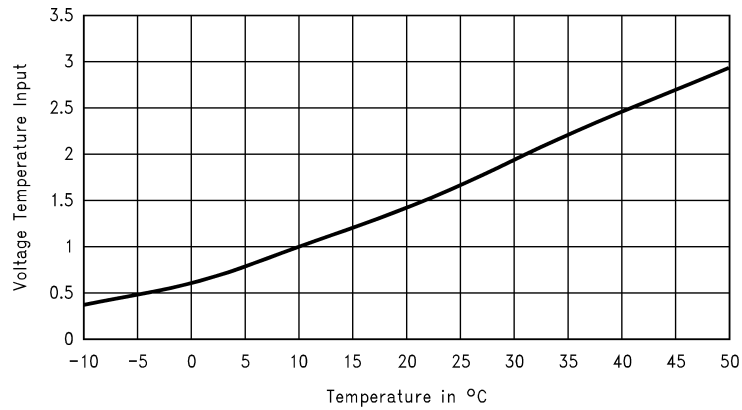

10131821

### 4.4 TYPICAL CIRCUIT CONFIGURATIONS

#### 4.4.1 Common Circuitry Used for both Ni-Cd/Ni-MH and Li-Ion

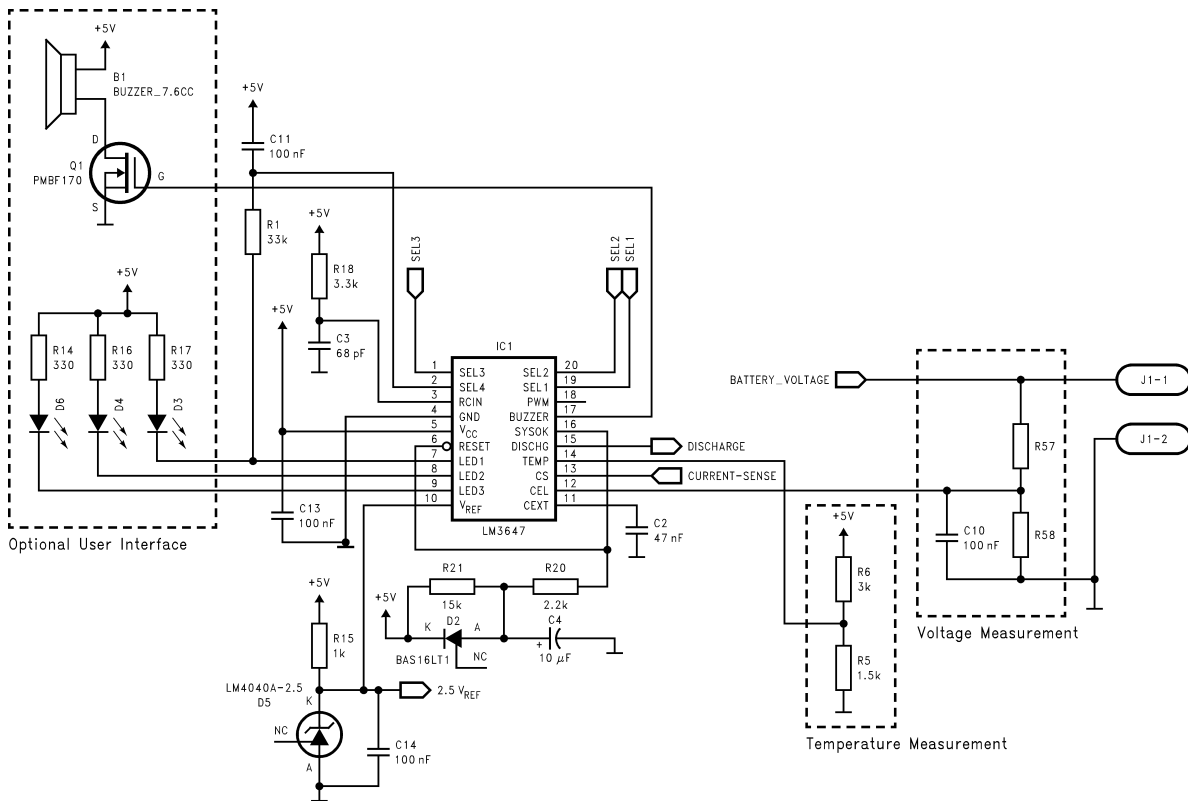

10131822

## 4.0 Functional Description (Continued)

### 4.4.2 Circuitry Used Only for Ni-Cd/Ni-MH

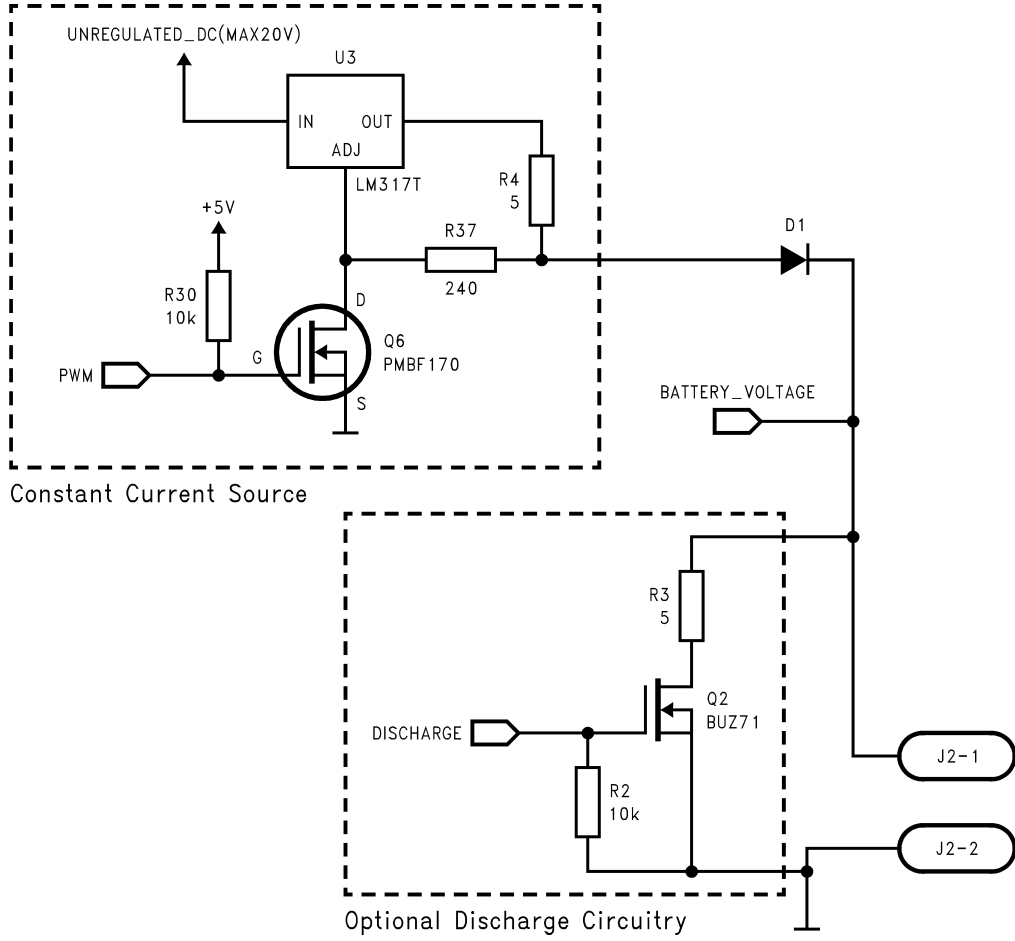

10131823

### 4.0 Functional Description (Continued)

#### 4.4.3 Circuitry Used for Li-Ion (can also be used for Ni-Cd and Ni-MH if those chemistries are to be supported with the same charger)

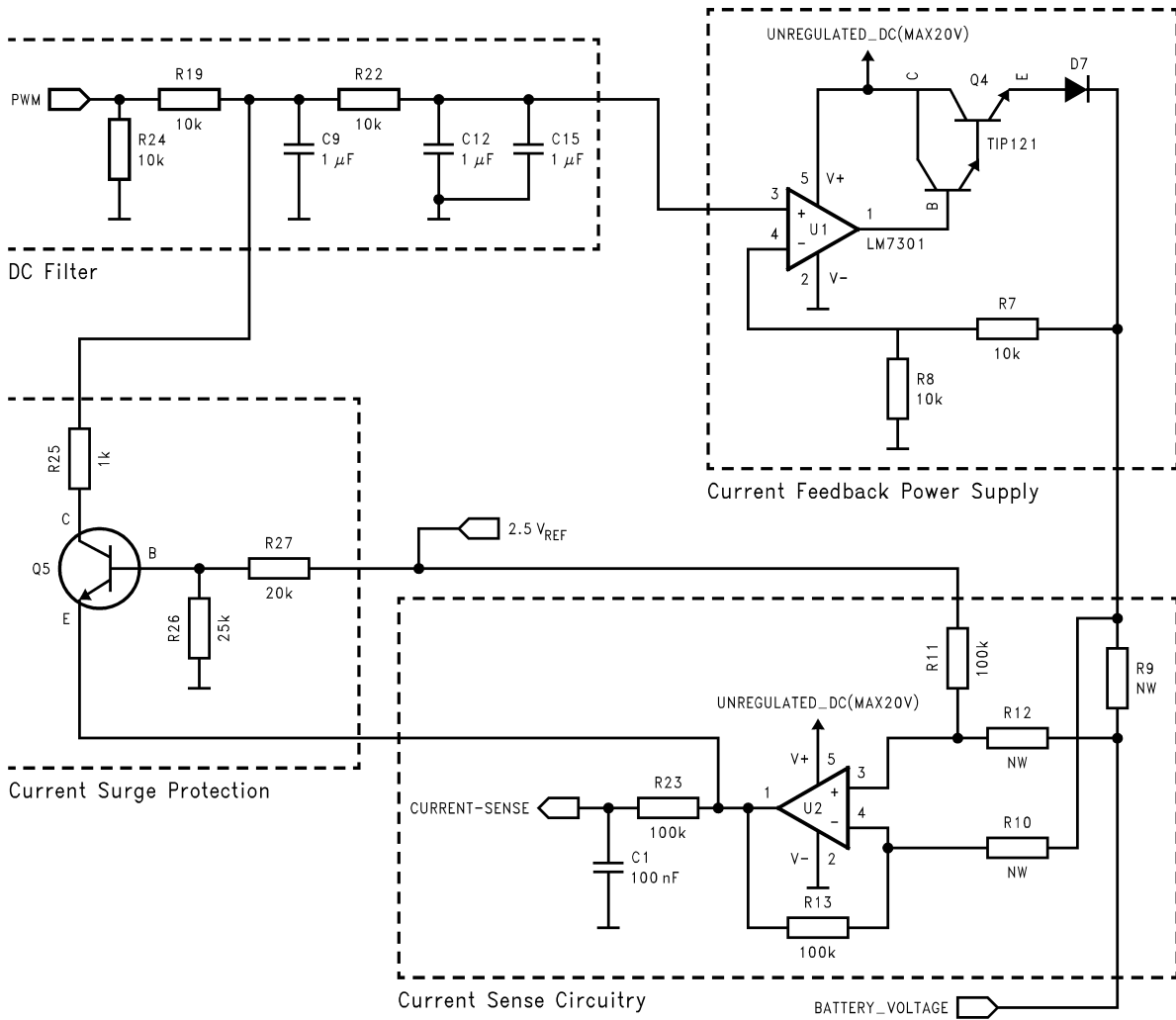

**Note:** D7 is required to protect Q4 from reverse current.

10131824

**Physical Dimensions** inches (millimeters) unless otherwise noted

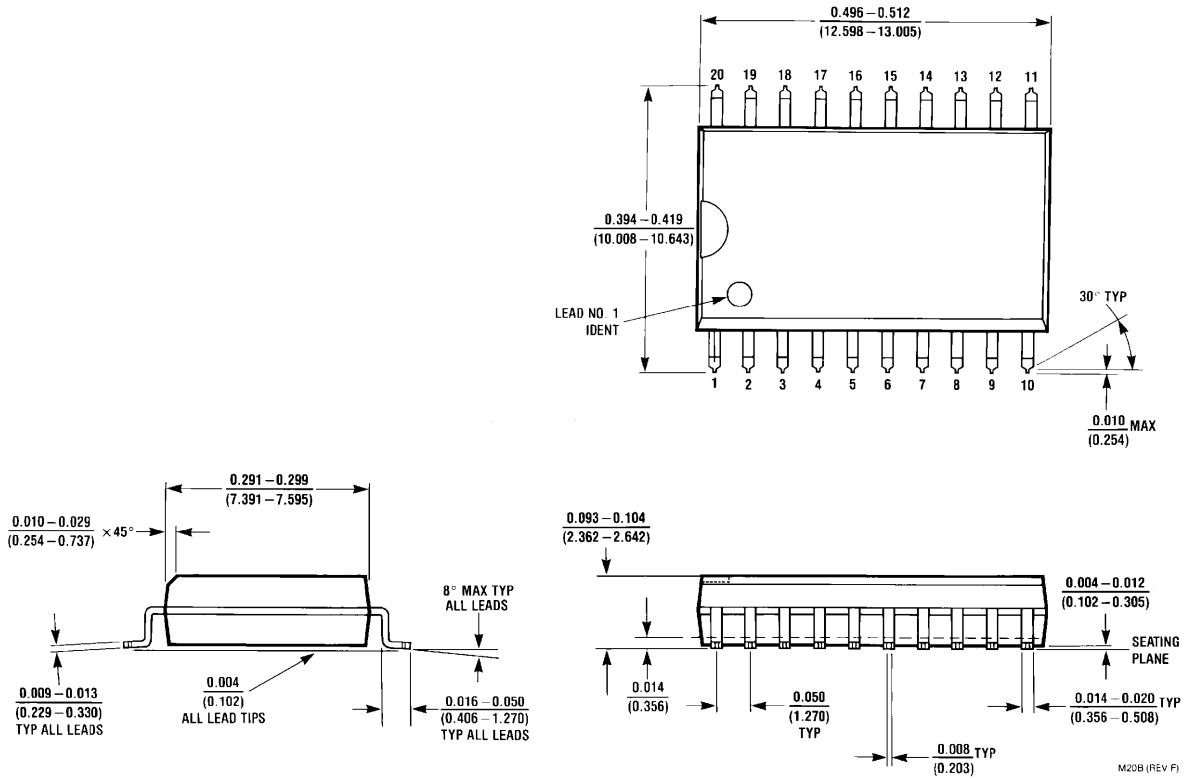

**Molded SO Wide Body Package (WM)**  
**Order Number LM3647IM**  
**NS Package Number M20B**

National does not assume any responsibility for use of any circuitry described, no circuit patent licenses are implied and National reserves the right at any time without notice to change said circuitry and specifications.

For the most current product information visit us at [www.national.com](http://www.national.com).

**LIFE SUPPORT POLICY**

NATIONAL'S PRODUCTS ARE NOT AUTHORIZED FOR USE AS CRITICAL COMPONENTS IN LIFE SUPPORT DEVICES OR SYSTEMS WITHOUT THE EXPRESS WRITTEN APPROVAL OF THE PRESIDENT AND GENERAL COUNSEL OF NATIONAL SEMICONDUCTOR CORPORATION. As used herein:

1. Life support devices or systems are devices or systems which, (a) are intended for surgical implant into the body, or (b) support or sustain life, and whose failure to perform when properly used in accordance with instructions for use provided in the labeling, can be reasonably expected to result in a significant injury to the user.
2. A critical component is any component of a life support device or system whose failure to perform can be reasonably expected to cause the failure of the life support device or system, or to affect its safety or effectiveness.

**BANNED SUBSTANCE COMPLIANCE**

National Semiconductor certifies that the products and packing materials meet the provisions of the Customer Products Stewardship Specification (CSP-9-111C2) and the Banned Substances and Materials of Interest Specification (CSP-9-111S2) and contain no "Banned Substances" as defined in CSP-9-111S2.

 **National Semiconductor**  
**Americas Customer Support Center**  
 Email: [new.feedback@nsc.com](mailto:new.feedback@nsc.com)  
 Tel: 1-800-272-9959

**National Semiconductor**  
**Europe Customer Support Center**  
 Fax: +49 (0) 180-530 85 86  
 Email: [europe.support@nsc.com](mailto:europe.support@nsc.com)  
 Deutsch Tel: +49 (0) 69 9508 6208  
 English Tel: +44 (0) 870 24 0 2171  
 Français Tel: +33 (0) 1 41 91 8790

**National Semiconductor**  
**Asia Pacific Customer Support Center**  
 Email: [ap.support@nsc.com](mailto:ap.support@nsc.com)

**National Semiconductor**  
**Japan Customer Support Center**  
 Fax: 81-3-5639-7507  
 Email: [jpn.feedback@nsc.com](mailto:jpn.feedback@nsc.com)  
 Tel: 81-3-5639-7560